

REV	BY	DATE	DESCRIPTION
-	LF	25.08.2021	ORIGINAL DRAWING
A	LF	02.10.2022	MOTOR IP55 (WAS IP54)
			21.03.2023 - REDUCTION IN THE NUMBER OF SPARE PARTS

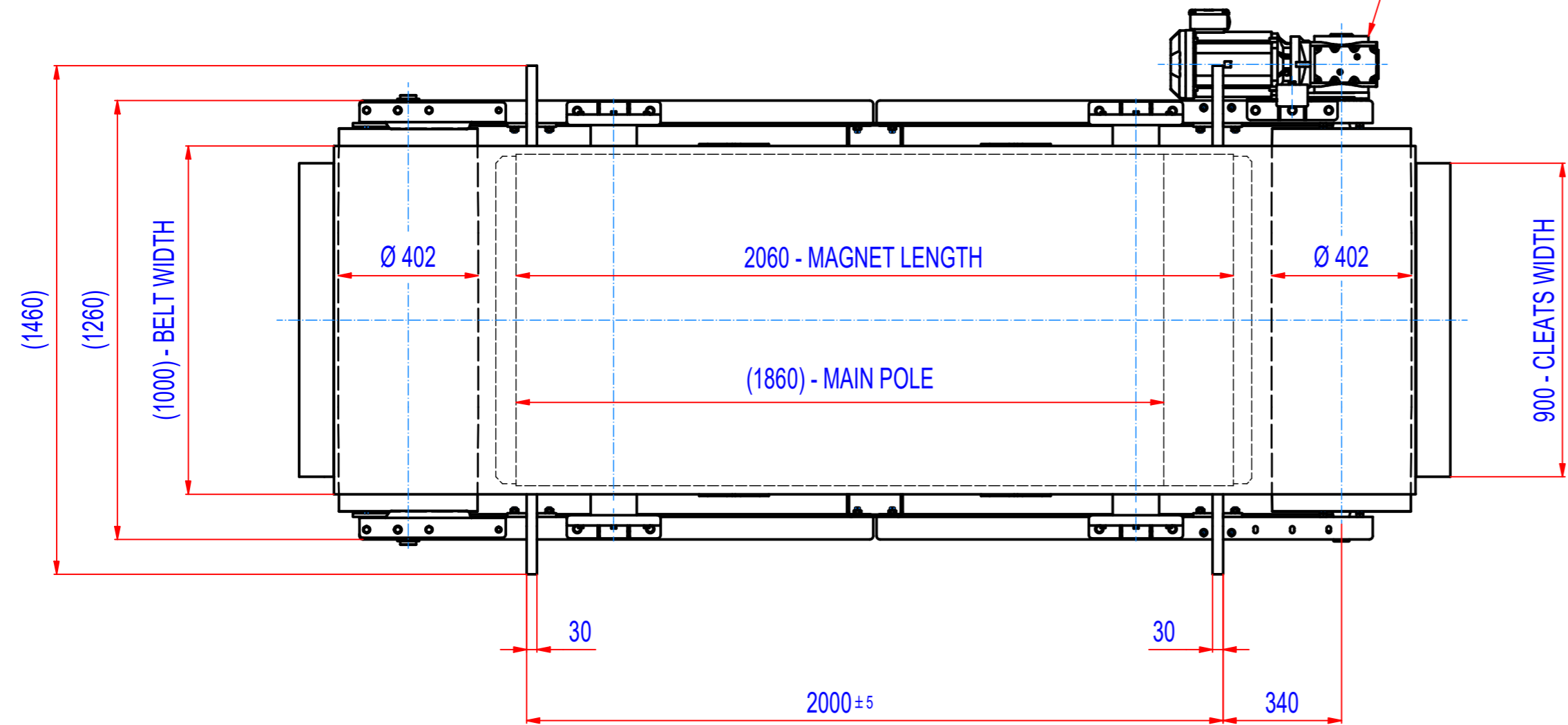
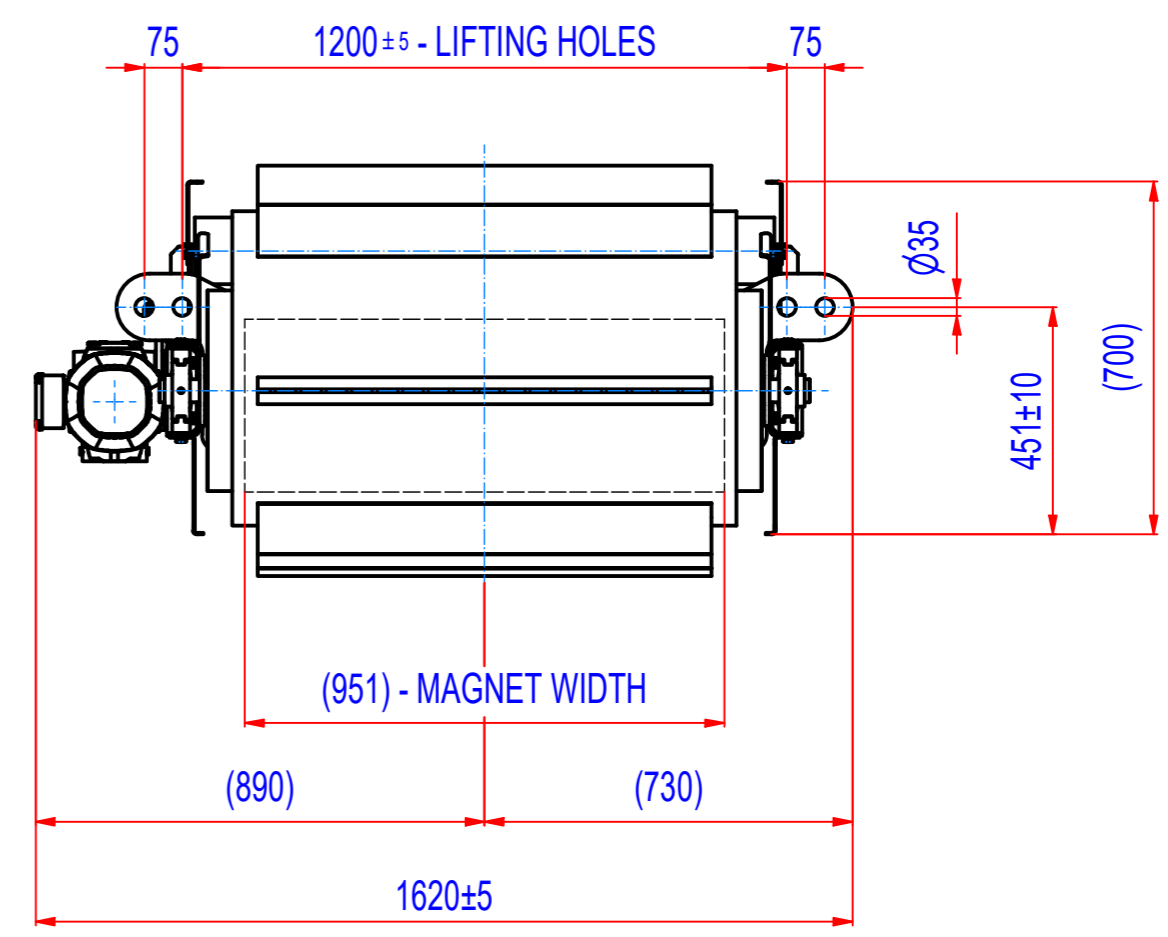
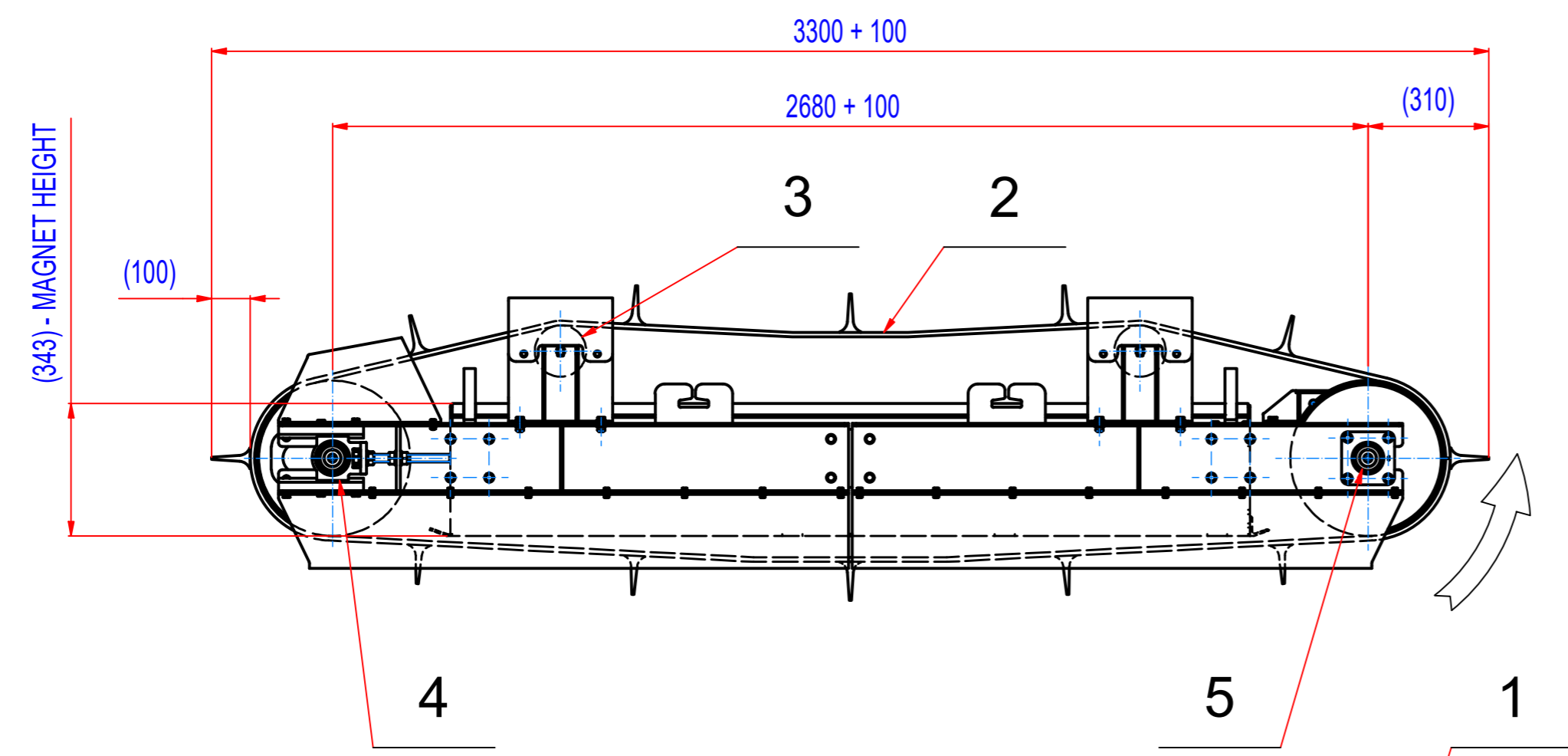

- GEARED BOX SEW SA67/TDRN100L4, i=20,37 (71RPM)
 MOTOR 230/400V, 3kW, 50Hz, IP55
 - DRUM SPEED 71/min
 - BELT SPEED 1,5 m/s
 - BELT EP500/4 5+2, LENGTH 6720, WIDTH 1000,
 12 CLEATS T100/10, WIDTH 900

5	15_8700045	BEARINGS ASSEMBLY INA PCJ 45		2,5	2
4	15_8600045	BEARINGS ASSEMBLY INA PTUE 45		2,7	2
3	1510_00009	PLAIN ROLLER 133x1150/6306		23,9	2
2	45_4100049	BELT EP500/4 5+2, W=1000, L=6720	RUBBER	115	1
1	M030007116	SEW SA67/TDRN100L4, 3kW, i=20,37 (71 RPM)		64	1
POZ.	Č. SOUČÁSTI	POPIS	MATERIÁL	HMOT.	MN.

Sheet: A2 Drawn: LF Date: 25.08.2021 Predecessor: SEPB180035 Quick search: XSPB 5 Description: SPARE PARTS FOR ROFC180350	Weight (kg): 3462,8 <small>© All rights reserved. Reproduction is not permitted without written permission of GOUDSMIT Magnetic Systems BV</small>	Extra info: General tolerance: ISO 2768 - cL Drawn according: ISO268; ISO1101; ISO2553 Status: Customer reference number: Product key: ROP-F5-C-180-W-G-L-B-B-NA Part number: ROFC180350_SP Rev: A
--	--	--