

REV	DATE	BY	DESCRIPTION
-	07.03.2020	LF	ORIGINAL DRAWING, 16.01.21 - MOTOR IP55
	17.07.2023		REDUCTION IN NUMBER OF SPARE PARTS
A	30.01.2024	LF	MOTOR 3kW (WAS 2,2kW)

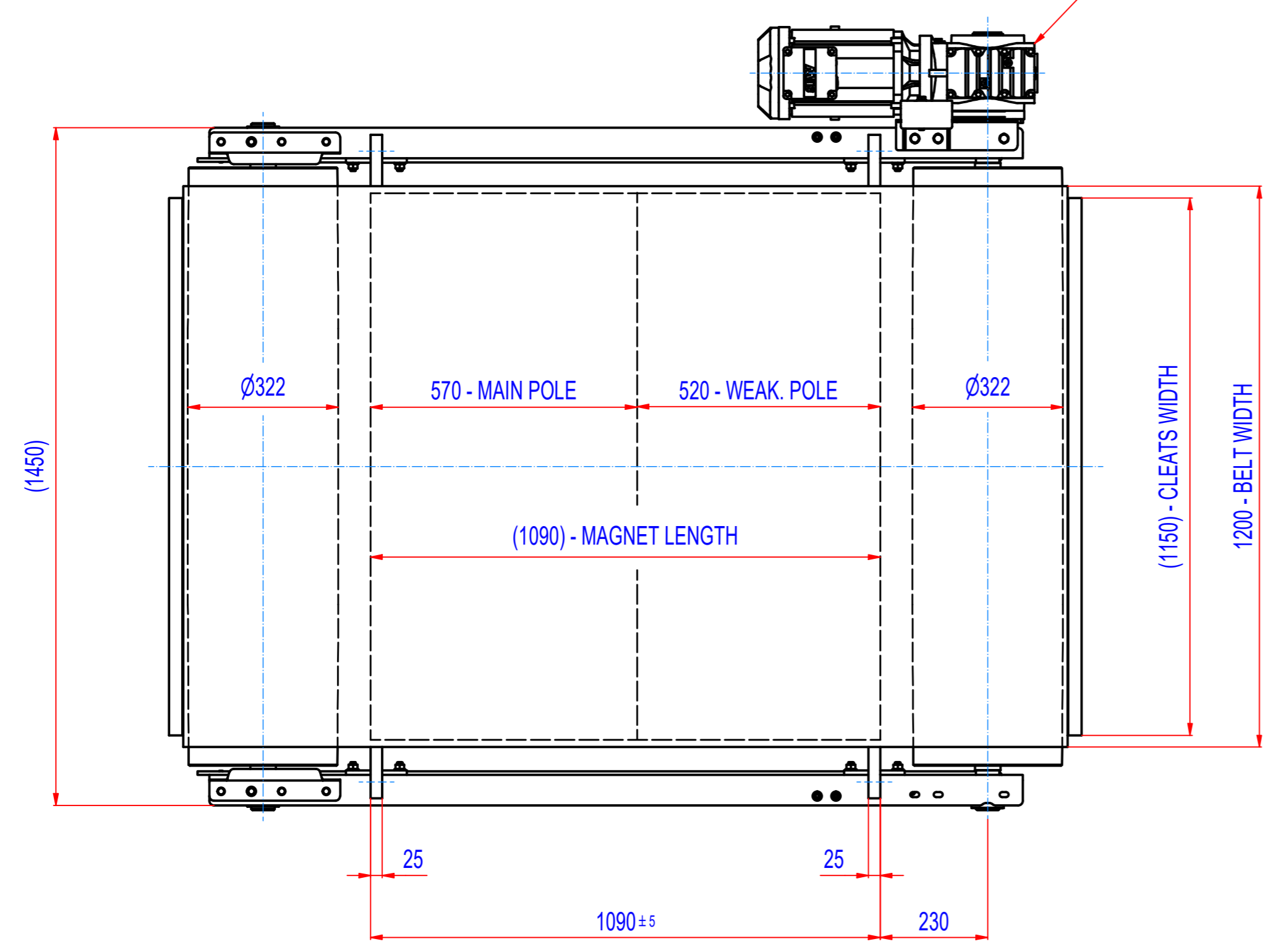
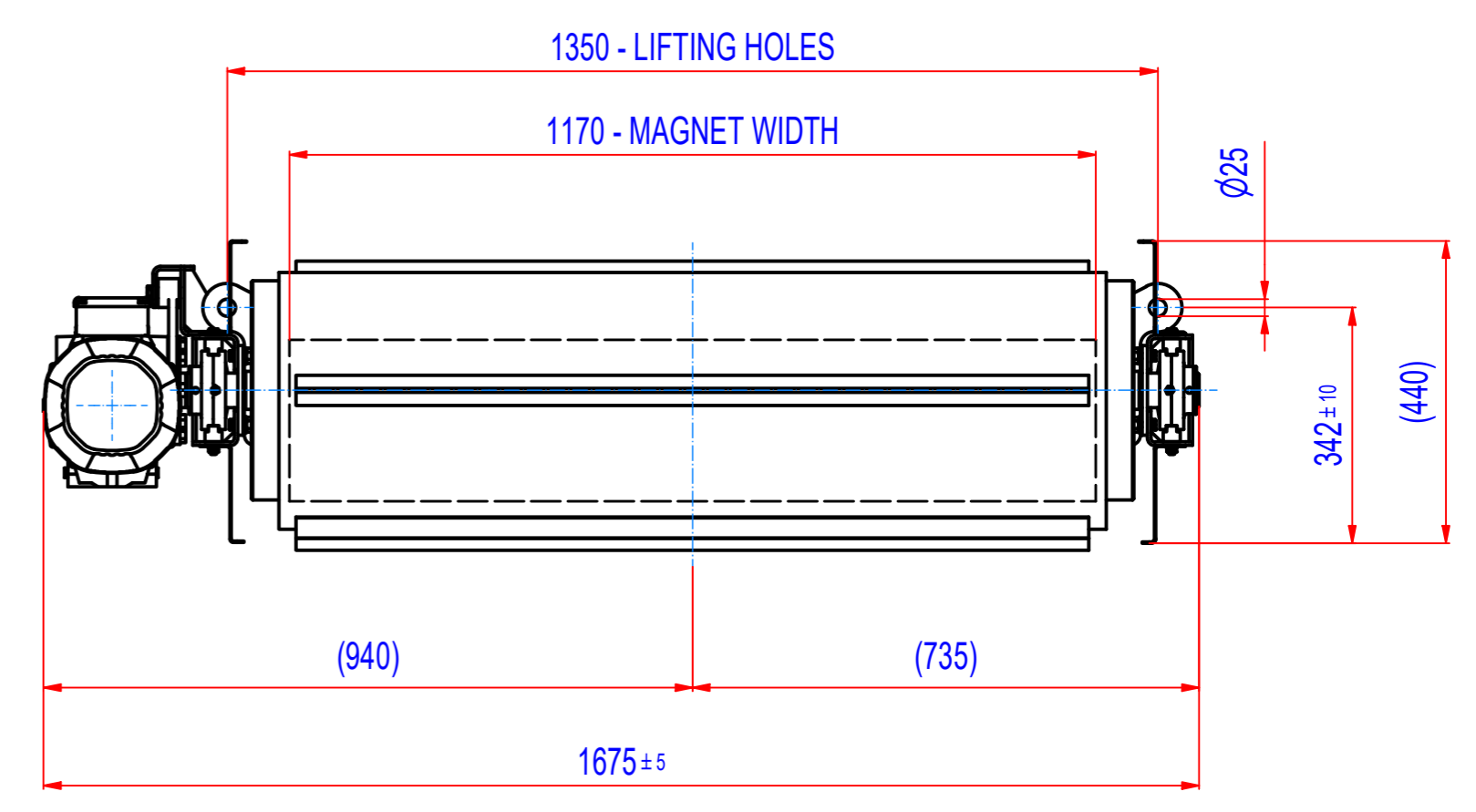
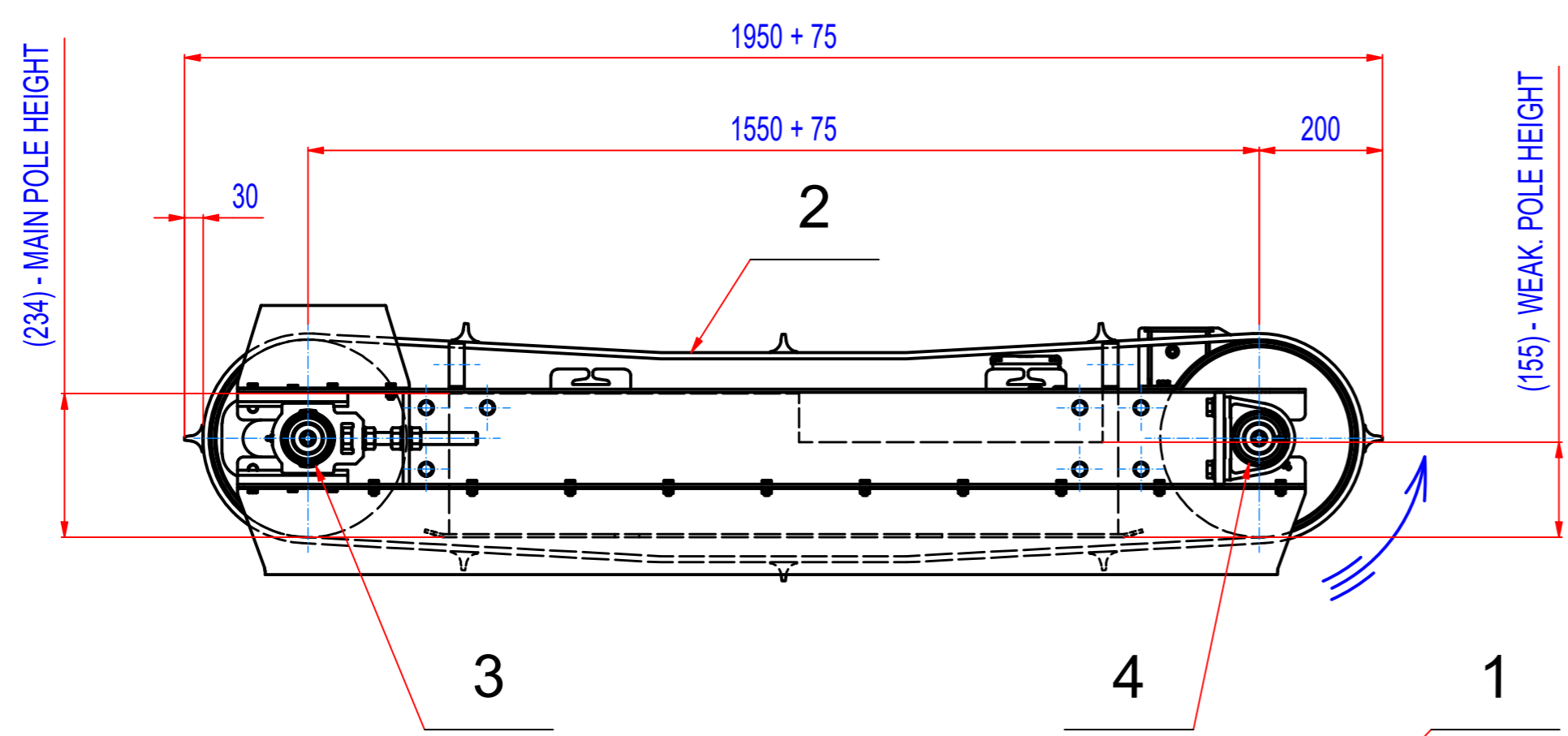

POZ.	Č. SOUČÁSTI	POPIS	MATERIÁL	HMOT.	MN.
4	15_8900050	BEARINGS ASSEMBLY INA PSHE 50		2,5	2
3	15_8600050	BEARINGS ASSEMBLY INA PTUE 50		2,4	2
2	45_4120020	PÁS / BELT EP 400/3 4+2, W=1200, L=4170	RUBBER	50,2	1
1	MO30009306	SEW SA67/TDRN100L4; 3 kW; i=15,6 (93RPM)		67,2	1

- GEARED BOX: SEW SA67/TDRN100L4, i=15,6 (93RPM),  
 MOTOR 3 kW, 230/400V, IP55  
 - DRUM SPEED 93/min  
 - BELT SPEED 1,55 m/s  
 - BELT EP400/3 4+2, WIDTH 1200, LENGTH 4170,  
 8 CLEATS T30/10, WIDTH 1150

Sheet: <b>A2</b> Drawn: <b>LF</b> Date: <b>16.7.2023</b> Predecessor:	Weight (kg): <b>1610,7</b> <b>GOUDSMIT</b> <b>MAGNETICS</b> <small>© All rights reserved. Reproduction is not permitted without written permission of GOUDSMIT Magnetic Systems BV</small>	Extra info: General tolerance: <b>ISO 2768 - cL</b> Drawn according: <b>ISO268; ISO1101; ISO2553</b> Status: Customer reference number: Product key: <b>ROP-F3-I-120-W-G-L-B-B-NA</b> Part number: <b>ROFI120330_SP</b> Rev: <b>A</b>
Quick search: <b>XSPB 3</b> Description: <b>SPARE PARTS FOR ROFI120330</b>		