

REV	DATE	BY	DESCRIPTION
-	07.03.2022	PH	ORIGINAL DRAWING

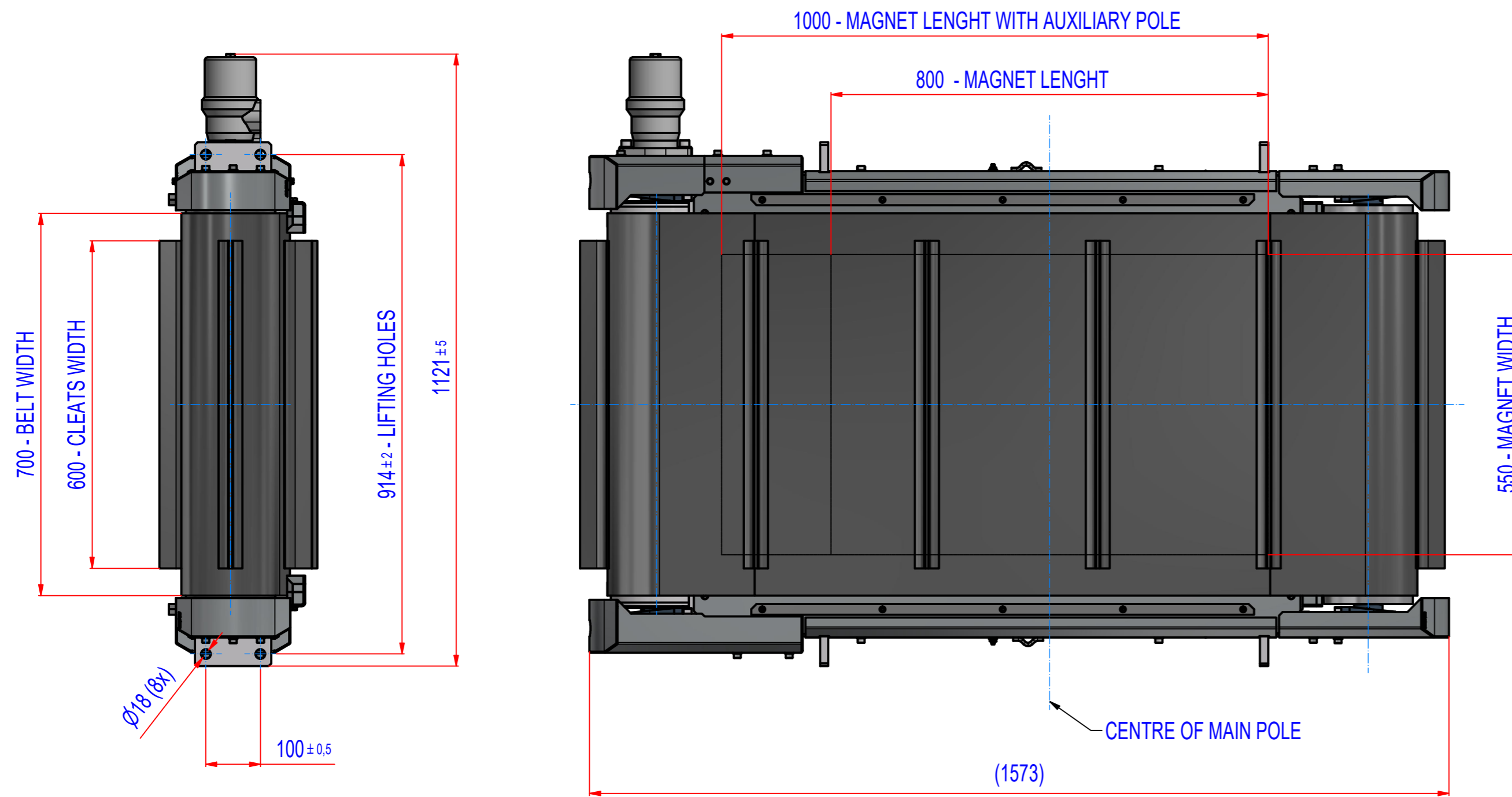
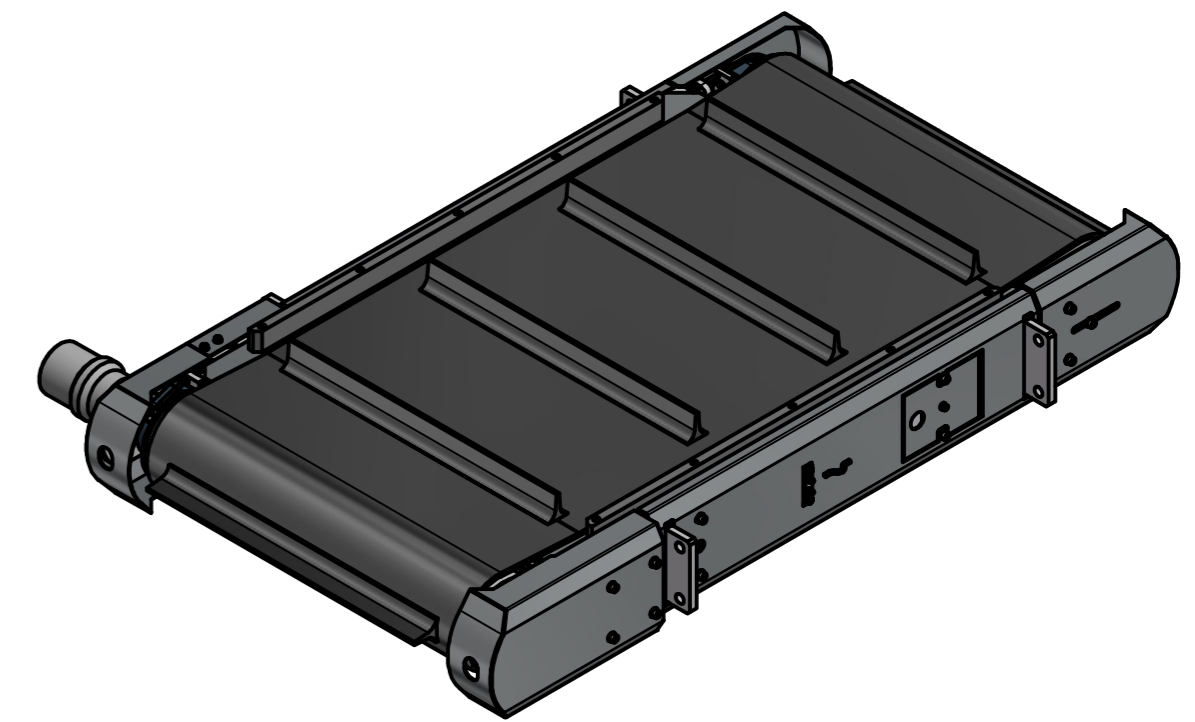
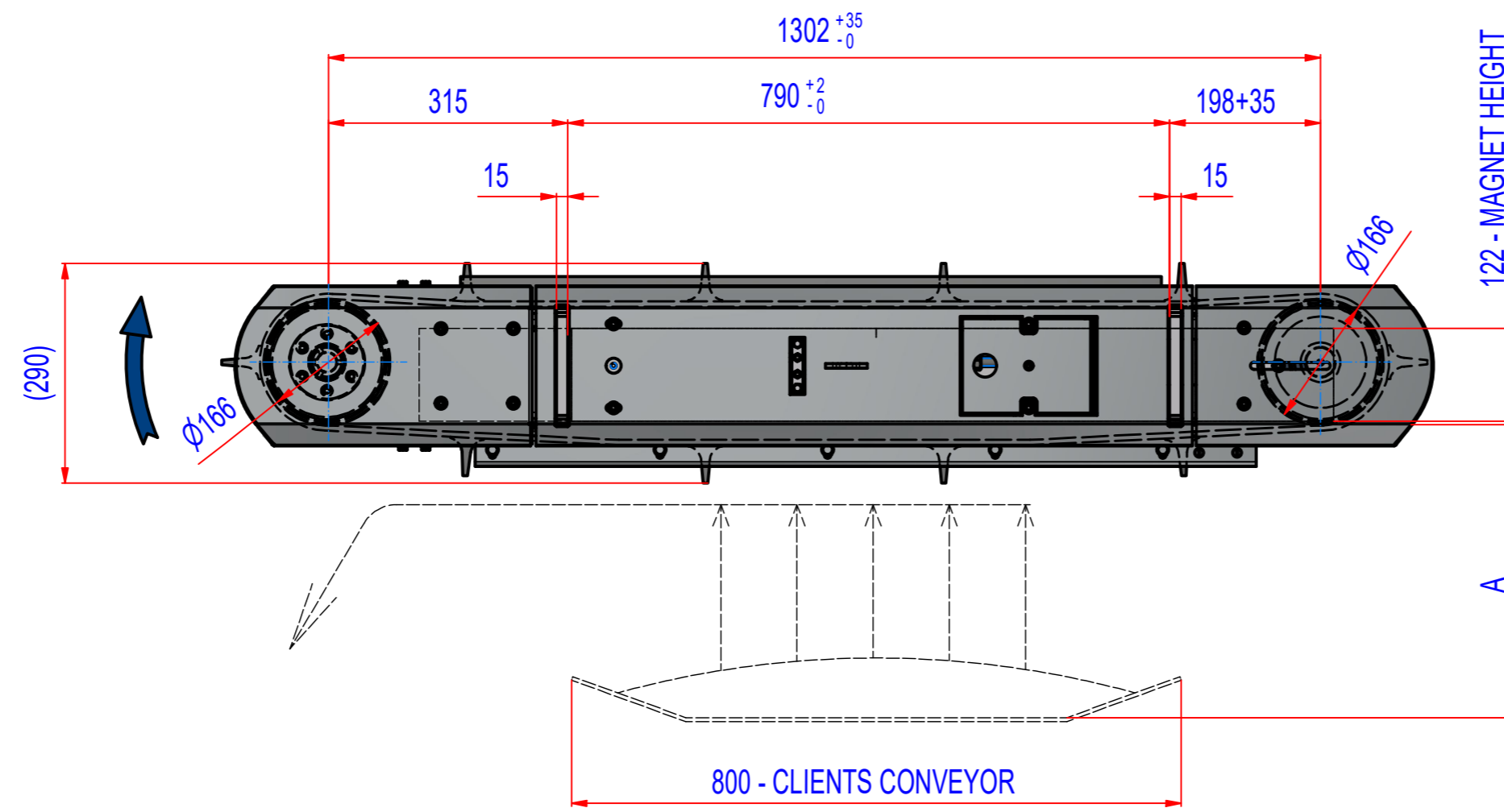

A = 390 mm - max. catch distance for rod Ø15, L=75 mm (VDE)
A = 310 mm - 400 Gs

MAGNET : MAGNETS NdFeB, FERRITTE, WATERPROOF
FRAME: MADE FROM AISI 304
PROTECT PLATES: AISI 304, 2-3mm
BELT TYPE: EP250/2 3+1,5, WIDTH 700, LENGTH 3160,
 10 CLEATS T50/20, WIDTH 600
MOTOR: Hydromotor OMR X 315, 11186652 (or equivalent)
ACCESSORIES: FRAME SIDE COVERS
 GREASING FROM LEFT AND RIGHT SIDE

	Sheet: A2	Extra info:	General tolerance: ISO 2768 - cL
Drawn: PH	Weight (kg): 544,4	<p>© All rights reserved. Reproduction is not permitted without written permission of GOUDSMIT Magnetic Systems BV</p>	Drawn according: ISO268; ISO1101; ISO2553
Date: 07.03.2022	Predecessor: RONC080341		Status:
Quick search: XSPB	Description: Overband separator, NdFeB, Size.4, W0800		Customer reference number:
			Part number: RONC080541
			Product key: ROP-N4-C-080-W-H-R-B-B-M-NA
			Rev: -