

Manual

Demagnetizing tunnel, HDTU series

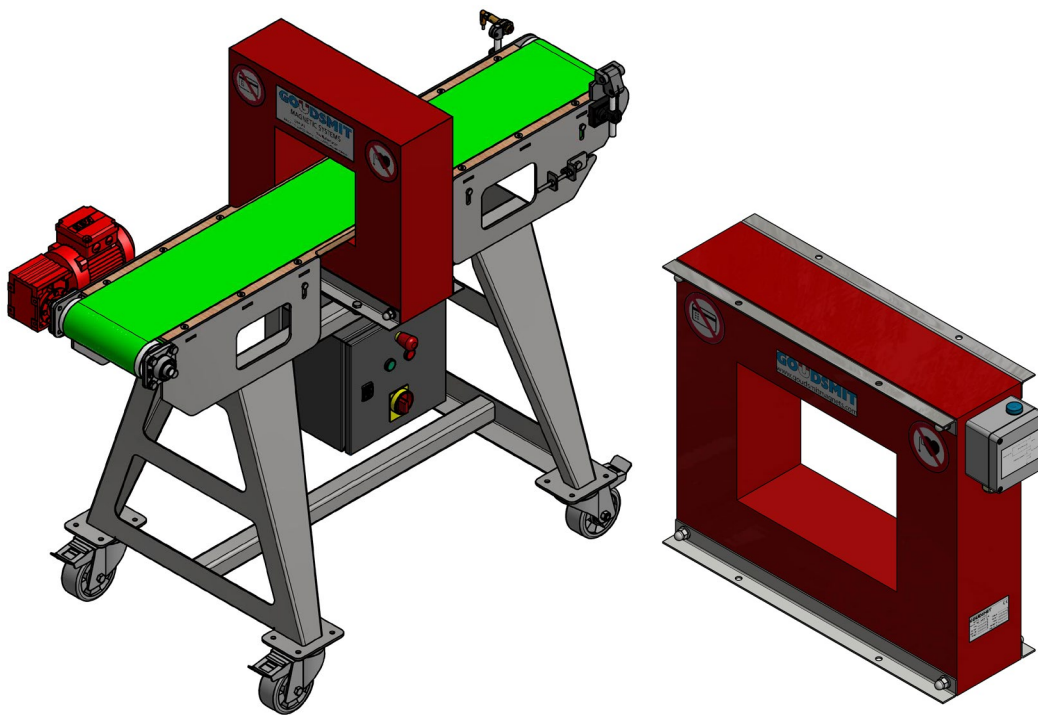

The illustrations in this manual may differ from your version

GOUDSMIT Magnetic Systems B.V.

PO Box 18
Petunialaan 19
Netherlands

5580 AA Waalre
5582 HA Waalre

Tel. : +31 (0)40 221 32 83

Internet : www.goudsmitmagnetics.nl

Email : info@goudsmitmagnetics.nl



Content

Content	2
Safety	3
Type plate	4
Device description	5
Operating principle	6
Demagnetizing	7
Construction	8
Installation, start-up and maintenance	9
Electrical connections at low-frequency demagnetization tunnel	10
Electrical connections at 230 V demagnetization tunnel	10
Electrical connections at high frequency (400 V) demagnetization tunnel	10
Optional electrical connections to be made by the customer for a demagnetization tunnel at 230 V and 400 V	11
Motor maintenance (if conveyor belt is included in delivery)	12
Tunnel OFF delay time of the Siemens LOGO! (if applicable)	13
Malfunctions / Storage	14

The information in this manual is to be used exclusively for the operation and maintenance of the device. The information may not be disclosed to third parties without our prior written consent.

Our devices and the data in our documentation are subject to change without prior notice, without any obligation to modify previously delivered devices.

Please ensure that everyone working with the equipment has access to all the necessary information.

Version 01/2026

Safety



Danger from strong magnetic fields

Ferromagnetic objects will be attracted if they are less than 30 cm away from the magnet. Any ferromagnetic tools or components may be attracted and damage the device.



Danger to persons with implanted medical devices

Persons using a pacemaker should not be within the magnetic field of the device.



Hazard to electronic and mechanical equipment

Magnetic data carriers or electronic and mechanical equipment may be irreparably damaged by the magnetic field.



Warning stickers

Make sure all warning stickers are legible. Replace stickers when they are no longer present or damaged.



General protection

Make use of all safety devices necessary for safe operation and maintenance. These can include overalls, safety glasses, hearing protection, helmet, safety shoes, etc.



Leave all covers and protective panels in place.



Danger of electric shock due to high voltage.

Ensure that all electrical connections are made by qualified personnel in accordance with all applicable laws and directives.

Type plate

GOUDSMIT
MAGNETICS



www.goudsmitmagnetics.com

Article no.:	Voltage:	[V]
Order no.:	Current:	[A]
Date:	Power:	[VA]
Weight:	[kg]	Frequency: [Hz]
Prot. class:	Duty cycle:	[%]

Make a note of the serial number on the type plate and keep it handy when contacting with questions about the device.

Device description

Intended use

Demagnetization tunnels with rectangular through-holes are frequently used for large-format materials that need to be demagnetized, possibly in combination with a conveyor system. They are suitable for demagnetizing drills, moulds, jigs, bolts, nuts and other fasteners, in addition to steel components for the automotive industry.

Demagnetizing tunnels with round passages are specifically designed for demagnetizing steel dust in air filtration systems, connecting pieces for push conveyors, steel grit for grit blasting, ball bearings, etc.

Protection class

The 230 Volt and high frequency devices have protection class IP55.

The low frequency devices have protection class IP66.

Temperature

Suitable for ambient temperature from -10 °C to +40 °C.

Coil temperature: Some devices have a temperature sensor that can be used to prevent overheating of the coil.



During demagnetization, the base may become hot.

Switch off the demagnetization tunnel after use. The safe operating cycle is 75%.

Free space

Keep sufficient space around the device for inspection, maintenance and cleaning.

Do not use ferromagnetic materials within 1 metre of the device. Use wood or plastic material to support the conveyor belt or demagnetization tunnel.

Vibrations

Avoid heavy vibrations on the demagnetization tunnel.

The demagnetization tunnel is filled with 2-component polyurethane.

Cleaning

Ensure that the device, especially the transit tunnel, is kept clean by regularly (daily) removing dust and dirt.

Magnetizing the product

If a product remains in the pass-through opening of the demagnetization tunnel while the demagnetization function is switched off, the product may be magnetized. Move the product to more than 1 metre outside the demagnetization tunnel before turning it off.

Temperature sensor PT1000 (option)

Optionally, the demagnetization tunnel can be equipped with a temperature sensor to observe temperature fluctuations.

The sensor can also be used to switch the demagnetization tunnel on and off within a (preset) temperature range, instead of the standard clixon (thermostatic switch).



Damage to the temperature sensor

Make sure there is no voltage on the connections of the temperature sensor.

Operating principle

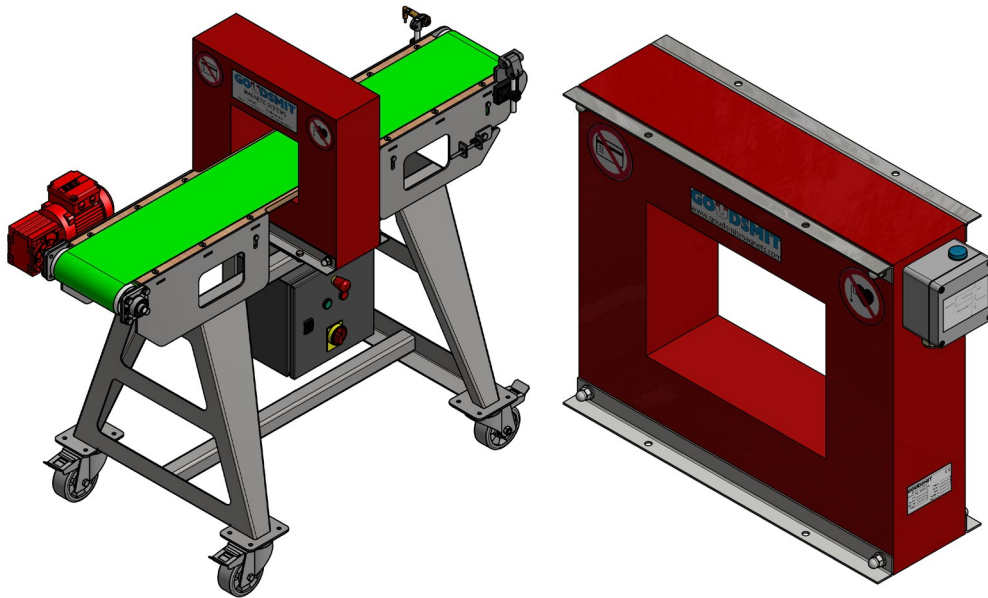

The demagnetization tunnel is a device that magnetically neutralises your products if they have become magnetized.

This magnetic neutralisation is achieved by creating a very powerful opposite magnetic field using an electromagnetic coil inside the tunnel that is operated by means of an electric control unit.

The product to be demagnetized has to be fed through the transit opening of the demagnetization tunnel to be demagnetized. This can be done manually or by a conveyor belt.

The undercarriage of the demagnetization tunnel must not contain any ferromagnetic parts as these can have a negative influence on the demagnetization process.



Note

During demagnetization, the direction of the product may affect the demagnetization result.

Demagnetizing**Demagnetizing tunnel without conveyor belt**

1. Make sure that the device is switched on.
2. Transport the material slowly and evenly through the tunnel spool. It is also possible to leave the product in the middle of the tunnel's transit opening for a short time.
3. Switch off the device after each demagnetization cycle.
4. Remove the product after demagnetization.
5. Measure the demagnetization result (with a Gauss meter) and repeat the demagnetization cycle if necessary.

Demagnetization tunnel with conveyor belt

1. Make sure that the device is switched on.
2. Place the product on the conveyor belt before starting the demagnetization cycle.
3. Start the conveyor belt.
4. Start the demagnetization cycle.

The product will be transported slowly and evenly through the tunnel transit opening. The moment the conveyor belt starts running, the demagnetization cycle must be started.

5. Stop the demagnetization cycle when the product has completely passed the tunnel.
6. Stop the conveyor belt and measure the demagnetization result (with a Gauss meter). Repeat the demagnetization cycle if necessary.
7. Remove the product from the conveyor belt.

Construction

The demagnetization tunnel is an electric coil enclosed by water-resistant and temperature-resistant polyurethane.

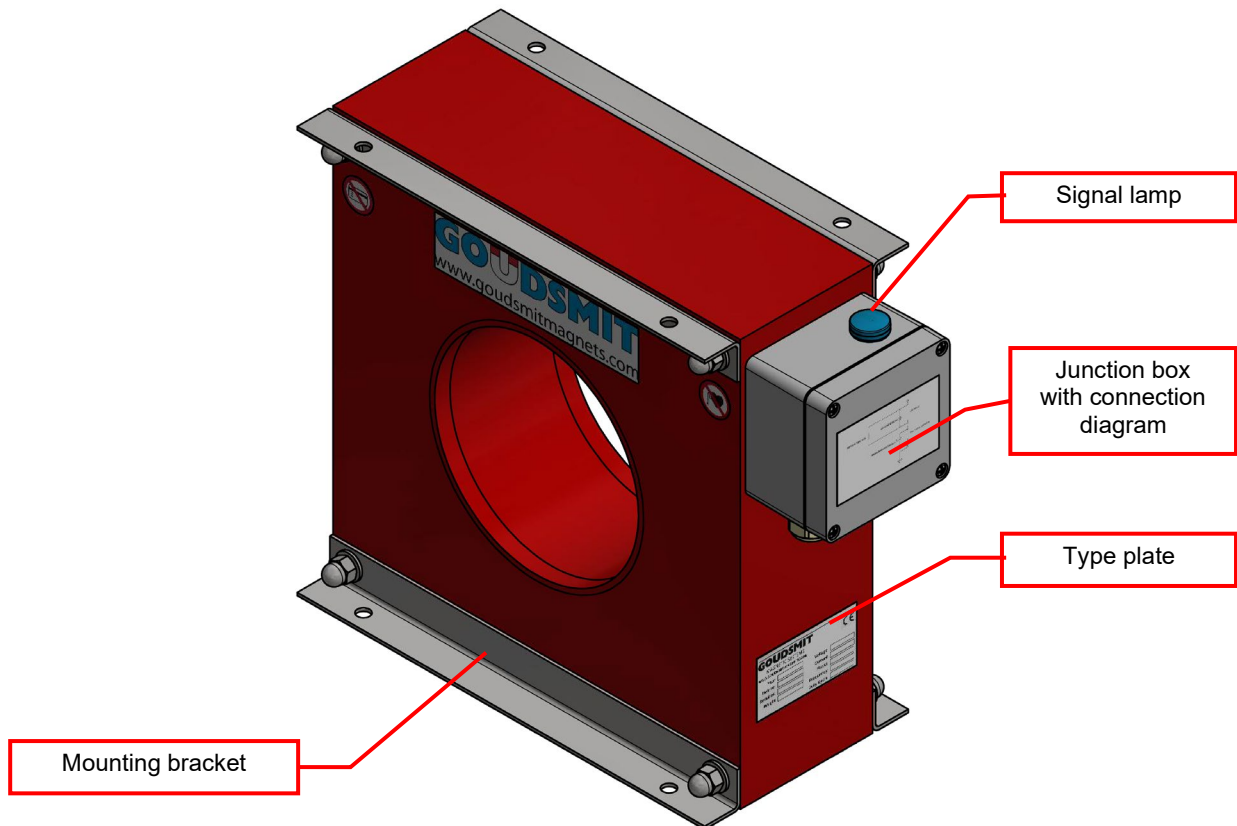

The demagnetization tunnel (without conveyor belt) comes with a junction box (IP55) with connection diagram on the lid. A signal lamp is attached. This lights up when the tunnel is in operation and demagnetizes.

The junction box contains 2 terminals for a temperature switch (clixon). The clixon switches off the demagnetization tunnel when the temperature exceeds 100 °C.



If the demagnetization tunnel is supplied without a junction box, use this signal to switch off the magnet in case it's short circuited or overheated (see examples on page [10](#)).

The technical data can be found on the type plate. Ensure that all connecting cables are suitable for the power consumption of the device.

Installation, start-up and maintenance

Installation

Only allow qualified personnel to work on the device according to national and local standards and regulations.

Mount the demagnetization tunnel correctly in place using a non-ferromagnetic base.

Place the demagnetization tunnel at the correct working height.

Setting up the device

The device can be set up in 2 directions:

- A vertical set-up where the demagnetization tunnel is upright and the product is passed through it horizontally.
- A horizontal set-up where the demagnetization tunnel lies flat and the products fall through it.

SET-UP

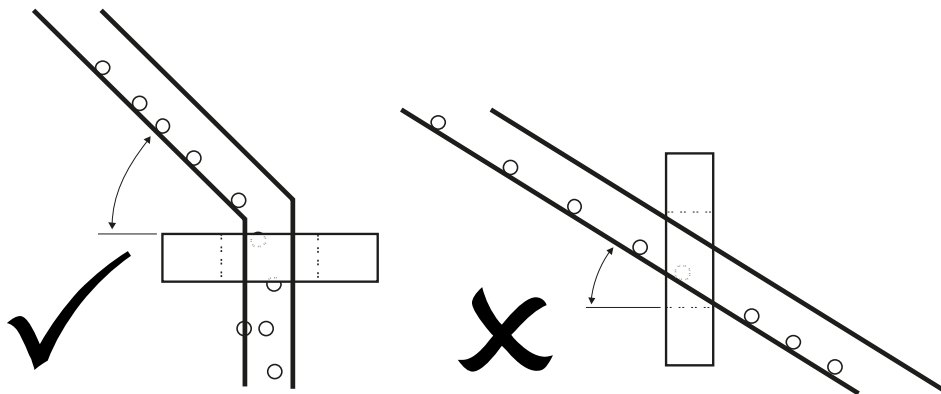

Products should be passed horizontally or vertically through the tunnel.

Area with non-ferromagnetic material

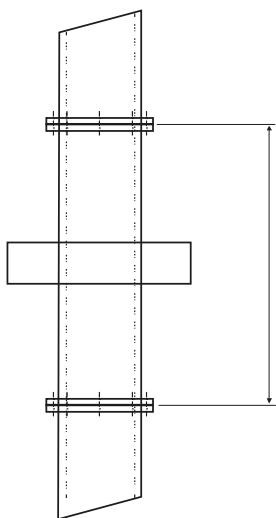

Ensure proper support.
Do not use a single plate or closed-loop frame.

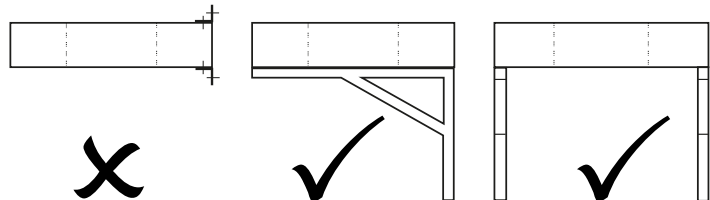

Use wood, plastic, stainless steel AISI316 (preferred) or AISI304

Optional electrical connections to be made by the customer for a demagnetization tunnel at 230 V and 400 V

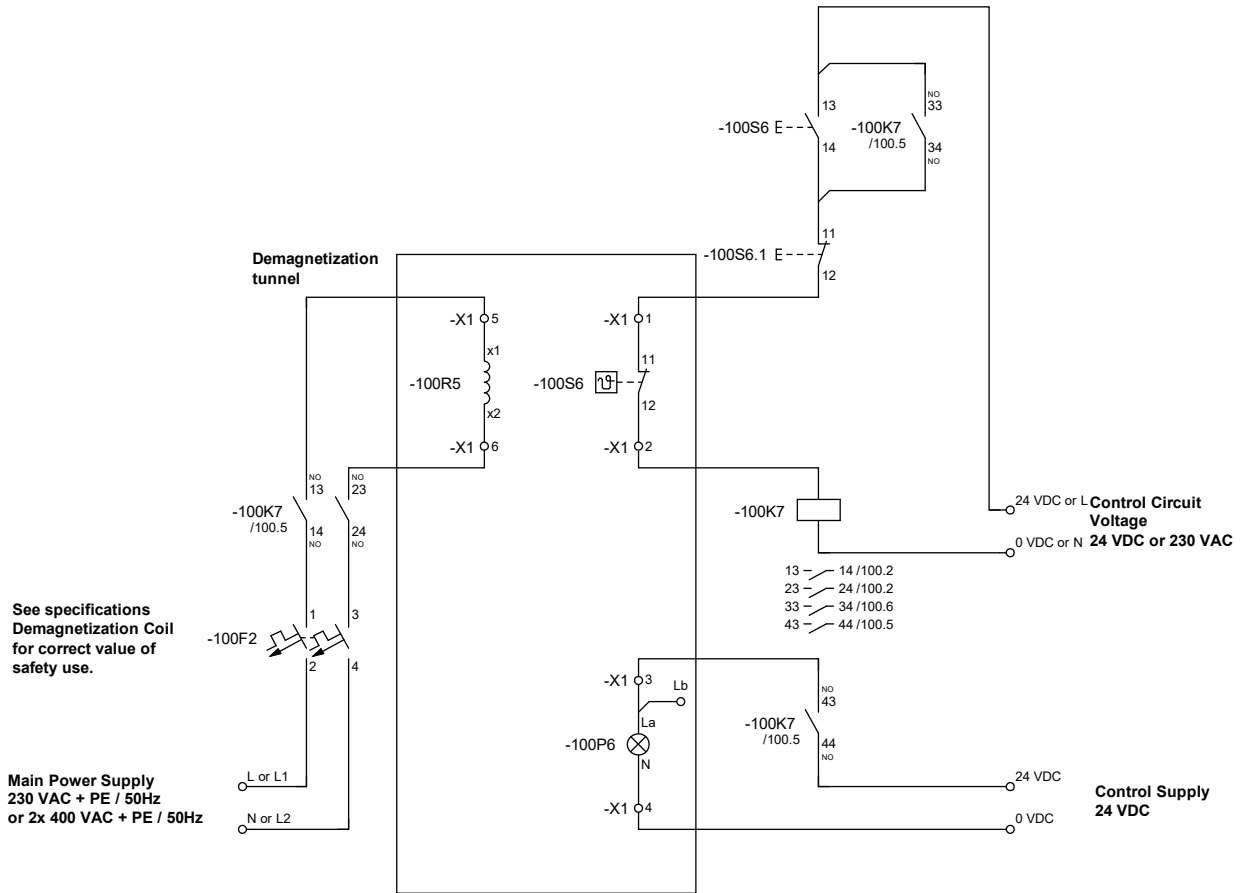

Motor maintenance (if conveyor belt is included in delivery)

Regularly check that the motor is not producing more noise than usual, and that it is warmer than usual. If it is, investigate what is causing it and fix the problem.

The table below gives general inspection and maintenance intervals as an indication of the necessary inspection and maintenance work.

REDUCER	
Interval	Work
<ul style="list-style-type: none"> Every 3,000 operating hours, at least every 6 months. 	<ul style="list-style-type: none"> Check the oil and oil level. Visually check the seals for leaks. For geared motors with a torque arm: check the rubber buffer and replace if necessary.
<ul style="list-style-type: none"> Depending on operating conditions (see chart below), at least every 3 years. Depending on oil temperature. 	<ul style="list-style-type: none"> Change the oil. Change the grease in the frictionless roller bearings (recommended). Replace the oil seal (do not fit it in the same track).
<ul style="list-style-type: none"> Depending on operating conditions (see chart below), at least every 5 years. Depending on oil temperature. 	<ul style="list-style-type: none"> Change the synthetic oil. Change the grease in the frictionless roller bearings (recommended). Replace the oil seal (do not fit it in the same track).
<ul style="list-style-type: none"> Some gearmotors (such as the SEW R07, R17, R27, F27 and Spiroplan®) are lubricated for life and therefore maintenance-free. 	
<ul style="list-style-type: none"> Various (depending on external factors). 	<ul style="list-style-type: none"> Update or renew the surface/rust-resistant coating.
MOTOR	
Interval	Work
<ul style="list-style-type: none"> Every 10,000 operating hours. 	Inspect the engine: <ul style="list-style-type: none"> Check the ball bearings and replace them if necessary. Replace the oil seal. Clean the cooling air vents.
	<p>[1] Operating hours</p> <p>[2] Exposure temperature of oil bath. Average value per oil type at 70 °C.</p> <p>[3] Most of our gearboxes use 0.4 litres of CLP PG NSF H1 Klubersynth UH1 6-460 oil.</p> <p>[4] The refreshment interval depends on the temperature.</p>

Table: General inspection and maintenance intervals for the motor.

Tunnel OFF delay time of the Siemens LOGO! (if applicable)

It is possible to change the tunnel OFF delay time by performing the following steps.

- *The parameters can be changed without stopping the programme!*

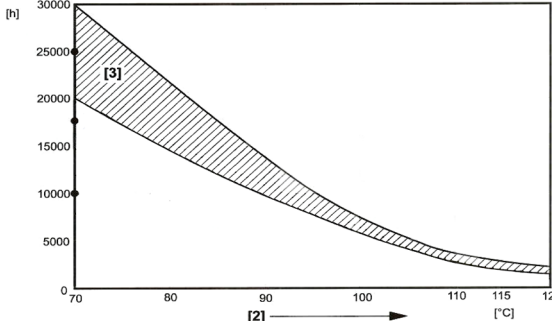
Changing the parameters must be done in "Set Param" mode.

To do so, the following procedure must be followed from the start screen:

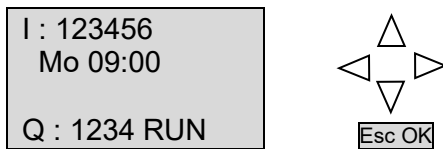

1. Press the **Esc** and **OK** key at the same time.

LOGO! enters the "Set Param" mode. The following display appears:

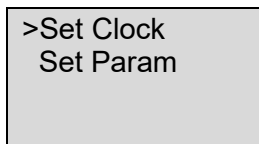

2. Press the **▼** key and switch to "**Set Param**". Press **OK** to confirm.

Three lines appear on the display:

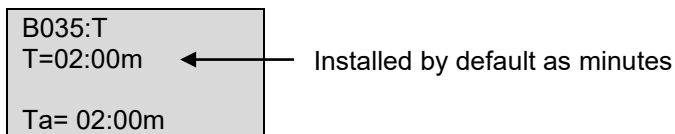

1. Block number with parameter (T)
2. Set value of this parameter (T) with its dimension (minutes: seconds)
3. The current value of the parameter in the active programme (Ta)

The cursor lights up in the B of block B08

3. a. Press the **▼** key and go to block B035.
b. To change the time, press the **▼** key and you will get to line **T=30:00m**.

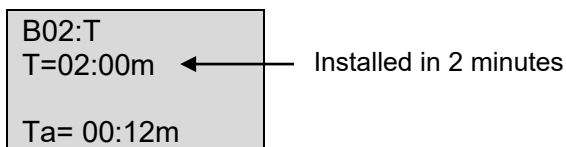

4. Press **OK** to change the parameter.
5. You can then use the **◀** and **▶** keys to move the cursor to the position to be adjusted.
6. Use the **▼** and **▲** keys to change the value.
7. Press **OK** to confirm the selected value.
8. Press **Esc** to return to the main menu. Press **Esc** twice to return to the start position.

You are now back in the start menu and the tunnel OFF delay time has been changed.

Complete manuals for the Siemens LOGO! can be found on the Siemens website.

Malfunctions / Storage

	CAUTION!
	<p>Improper handling of magnetic equipment can cause damage. Risk of personal injury and property damage!</p> <ul style="list-style-type: none"> • Any repairs to GOUDSMIT magnetic equipment must only be carried out by qualified personnel. • Be aware that permanent magnets can attract ferromagnetic material with great force when it comes within the range of the magnetic field. There is a danger of jamming! • Consult GOUDSMIT MAGNETIC SYSTEMS service.

Malfunctions

In case of malfunctions, refer to the table below to determine the cause and possible solution of the malfunction. If a specific malfunction cannot be determined from the table, contact GOUDSMIT Magnetic Systems customer service.

Malfunction	Possible cause	Possible solution
The demagnetization tunnel can no longer be switched on.	The thermostat (if included in delivery) inside the tunnel interrupted the power supply.	Let the tunnel coil cool down before switching it on again.
	The power supply is switched off.	Trace the cause and find a solution for it. Then reset the safety devices and/or fuses that have been activated.
The demagnetizing function does not work.	The demagnetizing function is not enabled.	Switch on the demagnetizing function.
	The thermostat (if included in the delivery) has interrupted the power supply.	Let the coil cool down. After the temperature has dropped below 75 °C, the power supply will automatically switch back on.
	The device is switched off due to short circuit or overload.	Trace the cause and find a solution for it. Then reset the safety devices and/or fuses that have been activated.

Storage and dismantling

The device must be disposed of at the end of its technical lifetime, correctly and in accordance with the local regulations.