

Installation and user manual

Pneumatically switchable magnetic sheet separators, type HSS-P...

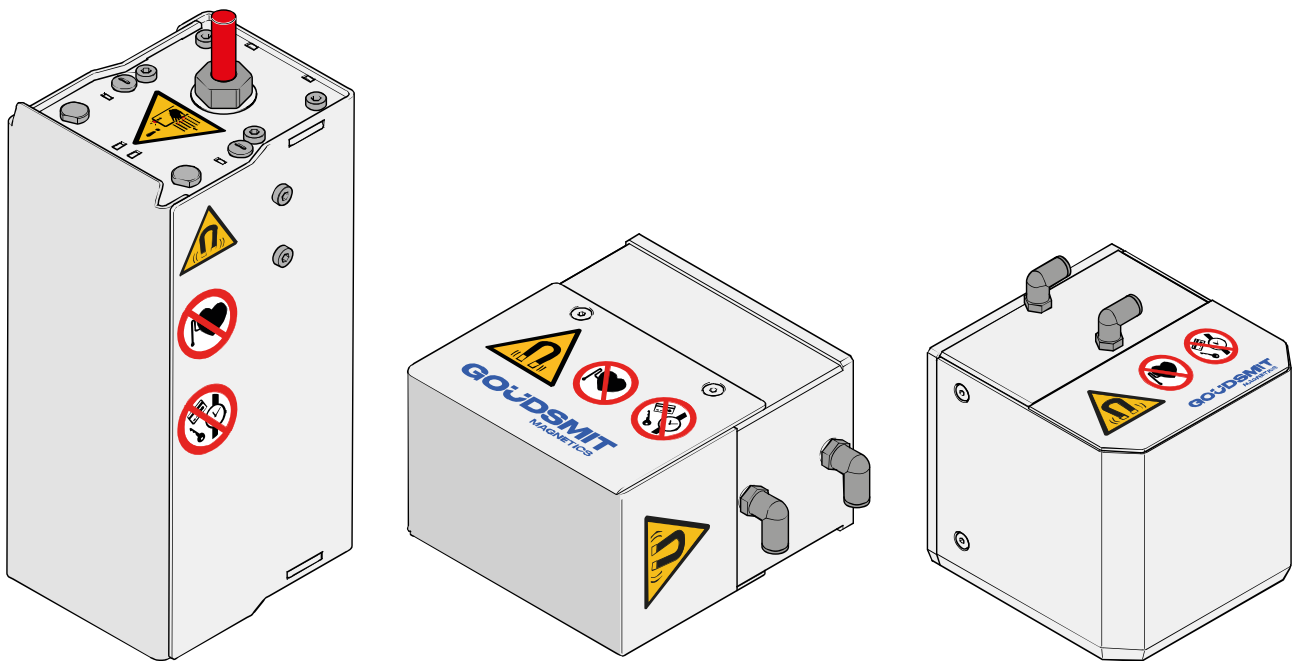

© Copyright. All rights reserved.

Table of contents

1 Introduction	5
2 Safety	6
2.1 Safety risks.....	6
2.2 General safety instructions.....	6
2.3 Emergencies	7
2.4 Damage due to magnetic field	7
2.5 Other remarks/warnings.....	7
3 Standards and directives	8
3.1 CE marking	8
3.2 Directives	8
3.3 Limit values for occupational and public exposure to permanent magnetic and electromagnetic fields.....	8
4 General information	9
4.1 Ferromagnetism	9
4.2 Warranty conditions	9
4.3 Other remarks/warnings.....	9
5 Specifications	10
5.1 Description of function.....	10
5.2 Extra safe thanks to 'fail-safe' design.....	10
5.3 Range of application	10
5.4 Temperature.....	10
5.5 Compressed air.....	11
5.6 Surface and corrosion protection	11
5.7 Lubrication of the device	11
5.8 Vibration and shocks.....	11
6 Product information	12
6.1 Scope of delivery.....	12
6.2 Overview drawing.....	12
6.3 Identification plate	13
6.4 Compressed air connections [5a/5b].....	13
6.5 Red indicator [1].....	13
6.6 Sensor connections [8a/8b].....	13
7 Transport and installation	14
7.1 Transport.....	14
7.2 Installation of the device.....	14
8 Commissioning	16
8.1 Connecting compressed air	16
8.2 Connecting pneumatically	17
8.3 Magnet on/off signalling via sensors (optional).....	17
9 Application and assembly examples	18
9.1 Assembly examples	18

- 10 Maintenance and inspection 19**
 - 10.1 Periodic inspection and maintenance 19
- 11 Troubleshooting 20**
- 12 Service, spare parts, storage and dismantling 21**
 - 12.1 Customer service 21
 - 12.2 Spare parts 21
 - 12.3 Storage and disposal 21

1 Introduction

This manual contains information about correct use and maintenance of the device. The manual contains instructions that should be followed to prevent injury and serious damage and to ensure safe and problem-free operation of the device. Read this manual thoroughly and ensure that you fully understand everything before using the device.

If you need more information or still have questions, please contact Goudsmit Magnetic Systems B.V.. The contact details are provided on the title page of this manual. Additional copies of the manual can be ordered by providing the device description and/or article number as well as the order number.

In this manual, the HSS magnetic sheet separator is further referred to as 'device'.



NOTICE

Read this manual carefully before installation and commissioning!

The descriptions and figures in this manual, provided for explanatory purposes, may differ from the descriptions and figures of your version.



NOTICE

This manual and manufacturer's declaration(s) are to be considered part of the device. Both documents must remain with this device if it is sold.

The manual must be available to all operating personnel, service technicians and others who work with the device throughout the life of the device.

2 Safety

2.1 Safety risks

This chapter describes the safety risks of the device. Where necessary, warning pictograms have been affixed to the device. These pictograms are explained later in this document.



NOTICE

Observe the following measures:

- ▶ Read the warning pictograms on the device carefully.
- ▶ Check that the pictograms on the device are present and legible at regular intervals.
- ▶ Keep the pictograms clean.
- ▶ Replace pictograms that have become illegible or that have been removed with new pictograms in the same locations.

2.2 General safety instructions



DANGER

Risk of entrapment due to strong magnetic fields

The magnets can cause severe and permanent injuries. Ferromagnetic objects are attracted when they come within a radius of 0.5 metres from the magnet.



WARNING

Risk of entrapment!

Do not carry out any cleaning or maintenance work inside the device while it is still in operation.

- The instructions in this manual must be complied with. If they are not, there is a risk of material damage, personal injury and even a danger of death.
- The device may only be used for separating steel sheets. Any other use is inconsistent with the regulations. Any resulting damage is not covered by the factory warranty.
- Ensure that people who work on the device or in its immediate vicinity wear adequate protective equipment.
- Keep at least 0.5 metres of clearance around the device. Provide clear markings to minimize danger to passersby. The markings must include a clear warning regarding the strong magnetic fields.
- Always leave all safety and shielding provisions in place if it is not necessary to remove them.
- Impose additional safety measures if the device remains easily accessible to people. If this is not possible, ensure that clear instructions are provided for the entire system in which this device is integrated.
- The device may only be operated remotely when all covers are in place and moving parts are inaccessible.
- Work on the device may only be carried out by qualified personnel. Ideally, maintenance work on the magnets should be carried out by Goudsmit Magnetic Systems B.V. personnel.
- Always observe locally applicable safety and environmental regulations.

2.3 Emergencies



WARNING

Switching off in case of emergency

The device does NOT have a safety switch. It is very important that your installation includes a provision for shutting off the compressed air supply to (i.e. depressurizing) the device in an emergency.

2.4 Damage due to magnetic field

The magnets generate a powerful magnetic field that attracts ferromagnetic particles. This also applies to ferrous materials that may be carried on the person, including keys, coins and tools. When working within the magnetic field, use non-ferromagnetic tools and workbenches with a wooden worktop and non-ferromagnetic base.



WARNING

Strong magnetic field

There is a risk of personal injury when carrying out work and measurement checks on the device. Do not place the fingers or other body parts between the magnetic components.

2.5 Other remarks/warnings

Rectify all faults before operating the device. If the device is used whilst exhibiting a fault, after having completed a risk assessment, warn operating and maintenance personnel of the fault and the potential risks associated with that fault.

3 Standards and directives

3.1 CE marking

In terms of construction and operation, this device complies with European and national requirements.



The CE marking confirms the conformity of the device with all applicable EU regulations associated with the application of this marking.

3.2 Directives

The standard version of this device conforms to the requirements of the following European directives:

- Machinery directive 2006/42/EC
- EMC directive 2014/30/EU

3.3 Limit values for occupational and public exposure to permanent magnetic and electromagnetic fields

The limit values and magnetic fields are defined in accordance with the EMC Directive 2013/35/EU as follows:

Directive 2013/35/EU of the European Parliament and of the Council of 26 June 2013 on the minimum health and safety requirements regarding the exposure of workers to the risks arising from physical agents (electromagnetic fields).

Observe the following measures in relation to exposure to magnetic fields in accordance with EN12198-1 (machine category = 0, no restrictions) of the device:

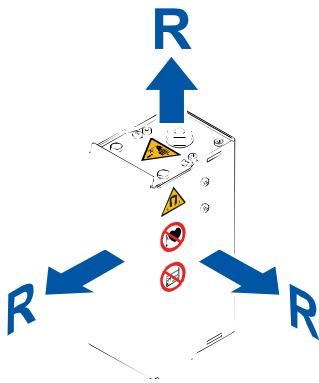

Life-threatening danger to people with implanted medical aids

People with an active implanted medical aid (e.g. pacemaker, defibrillator, insulin pump) may never be present within a radius 'R' of 1 metre(s) of the device.



Damage to products with sensitivity to magnets

Products that contain ferromagnetic parts, such as debit cards, credit or chip cards, keys and watches, may be rendered permanently damaged if they come within a radius 'R' of 0.5 metre(s) of the device.



Employees who are pregnant and the general public may not come within a radius 'R' of 0.04 metre(s) of the device.

Limit values for occupational exposure (general and for limbs) are not exceeded.

4 General information

4.1 Ferromagnetism

The device's principle of operation is based on ferromagnetism. Ferromagnetism is a property possessed by certain materials, such as iron, cobalt and nickel. These materials can become magnetized when exposed to an externally applied magnetic field. Materials that remain magnetized after the external magnetic field is removed are called permanent magnets or magnetically hard.

However, most magnetic materials lose their magnetism after the external magnetic field is removed. These are soft magnetic materials. Most alloys of iron, cobalt and nickel are magnetic.

However, some stainless steel alloys, such as AISI304 or AISI316, are only slightly magnetic.

4.2 Warranty conditions

The warranty on the device is void if:

- Service and maintenance are not performed in accordance with the operating instructions or are carried out by personnel not specially trained for this purpose. Goudsmit Magnetic Systems B.V. recommends having service and maintenance carried out by service technicians from Goudsmit Magnetic Systems B.V..
- Modifications to the device are carried out without our prior written consent.
- Parts of the device are replaced with non-OEM or non-identical parts.
- Parts of the device become damaged, because the device was put into production with a malfunction and/or a persistent malfunction.
- The device is used injudiciously, incorrectly, carelessly or in a manner not in keeping with its nature and/or intended use.



NOTICE

All parts subject to wear and tear are excluded from warranty.

4.3 Other remarks/warnings

- Do not use the device if it is damaged.
- Only use the device for the application for which it was designed.
- Ensure that the device is maintained correctly and in accordance with the instructions in this manual.
- Rectify all faults before operating the device.

5 Specifications

5.1 Description of function

The Fail Safe magnetic sheet separators are designed for the automatic separation and de-stacking of steel sheets. Steel sheets are often difficult to pick up from a stack when coated with a corrosion-resistant oil film, causing them to stick together. The presence of burrs resulting from cutting processes can also cause steel sheets to stick together.

This creates the risk that two or more sheets are lifted together and fed into the production machine.

This can cause significant damage, for example, when feeding into a 3D moulding die where there is no space for a double sheet.

In addition, when lifting a steel sheet from a stack, a vacuum is created between the lifted sheet and the stack. This vacuum can lead to significant lifting forces, especially with larger sheet sizes, particularly as the transport speed increases.

The devices use powerful neodymium magnets to strongly magnetize the steel sheets, effectively turning each sheet into a magnet.

Because like magnetic poles repel each other, the repulsive forces push the top sheets apart, creating space between the steel sheets so that a vacuum or magnetic gripper can easily lift only the top steel sheet.

5.2 Extra safe thanks to 'fail-safe' design

The switchable sheet separator is the only one of its kind equipped with a spring-loaded off position. This provides extra safety. In the event of an emergency stop or interruption of the compressed air supply, the device automatically switches to a spring-loaded off position, eliminating the dangerous magnetic field. Even under full load with maximum stack height, the device switches off. The device will therefore never be unintentionally switched on, thereby minimizing the risk of fingers being pinched between the steel sheets and the device. In addition, the device is equipped with a clear red indicator that shows when the device is 'ON'. If the indicator is not visible, the device is 'OFF'.

5.3 Range of application

The Fail Safe magnetic sheet separators are suitable for separating ferromagnetic steel sheets up to a thickness of 4 millimetres.

Steel sheets thicker than 4 mm typically do not require a sheet separator, as a possible second sheet detaches due to its own weight and remains on the stack. In some cases, when there is a significant amount of sticky oil present, it may still happen that a second sheet does not detach. In that case, a sheet separator can still be helpful. The magnetic force will not separate the top sheet from the stack, but when the sheet is lifted, the magnetic force will peel off the second sheet, causing it to remain on the stack.

The devices are suitable for separating steel sheets of all shapes and sizes, including round or asymmetrical shapes. For large sheet sizes, it may be necessary to install multiple sheet separators for effective separation. In the case of clean, non-oiled steel sheets, the sheet separators effectively separate an area of up to approximately 34 dm². For steel sheets that are sticky, due to oil or burrs, the effective area may be reduced to approximately 22 dm².

5.4 Temperature

Suitable for use in ambient temperature from +5 to +45 °C.

Take measures to prevent freezing, as moisture in the compressed air system can freeze below 5 °C, potentially damaging seals and causing malfunctions or jamming.

Avoid use in ambient temperatures above 45 °C. These high temperatures affect the magnetic force and spring resilience, and can cause air leakage and wear, as the applied lubricants no longer function optimally. All of this can lead to malfunctions.

The device is constructed with permanent magnets, which are sensitive to temperature changes. High temperatures cause a permanent loss of magnetic strength. Ensure that the magnets are not exposed to temperatures higher than 70 °C.

5.5 Compressed air

Connect the unit to compressed air of sufficient pressure to ensure proper operation:

Type	Minimum operating pressure [bar]	Maximum operating pressure [bar]
TPSP000017	4	6
TPSP000018	4	6
TPSP123301	5	10
TPSP124501	5	10
TPSP125301	6	10
TPSP126001	7.5 - 8	10

Table 1: Operating pressures

5.6 Surface and corrosion protection

The device is composed of stainless steel parts, anodized aluminium parts and nickel-plated steel parts. The corrosion protection is more than adequate for use in technical production environments.

5.7 Lubrication of the device

The device has maintenance-free bearings, and the pneumatic cylinder is factory lubricated for life. The device can be used without further lubrication.

5.8 Vibration and shocks

Although the device is built with heavy-duty construction and robust design to withstand the high loads resulting from its use in the steel industry, it is still important to avoid or prevent extreme vibration, shocks and mechanical stresses.

6 Product information

6.1 Scope of delivery

Check the shipment immediately upon delivery for:

- Possible damage and/or shortcomings as a consequence of transport. In the event of damage, ask the carrier for a transport damage report.
- Completeness.



NOTICE

In the event of damage or incorrect shipment, contact Goudsmit Magnetics immediately. The contact details are provided on the title page of this manual.

6.2 Overview drawing

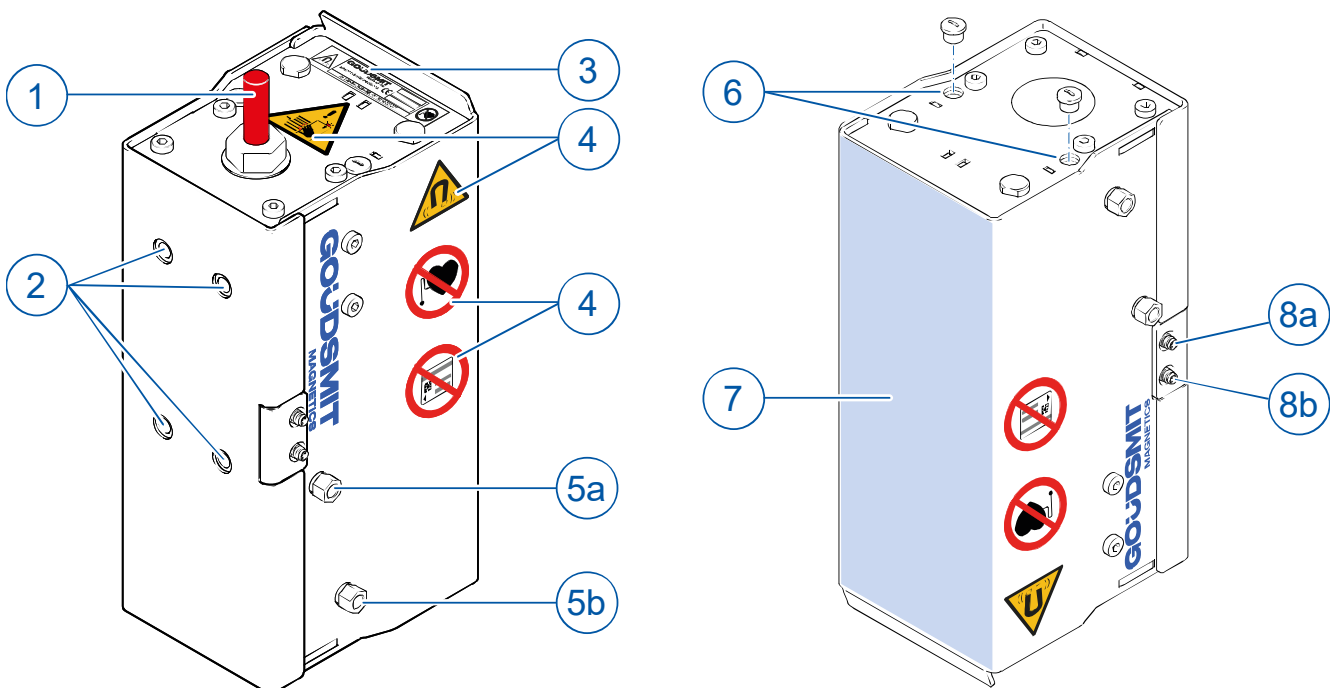

- [1] Red indicator (magnet active)
- [2] M8 threaded mounting holes (4x) on back
- [3] Identification plate
- [4] Warning pictograms
- [5a] G1/8" compressed air connection (magnet OUT)
- [5b] G1/8" compressed air connection (magnet IN)
- [6] M12 threaded mounting holes (2x) on bottom
- [7] Magnetic system's active surface
- [8a] Connection for ON sensor
- [8b] Connection for OFF sensor

6.3 Identification plate

The following identification data are shown on the device. The identification data are very important for maintenance of the device.

Always keep the identification data clean and legible. Always provide the article and order numbers when ordering spare parts, requesting service or reporting a malfunction.

Never remove the identification plate!

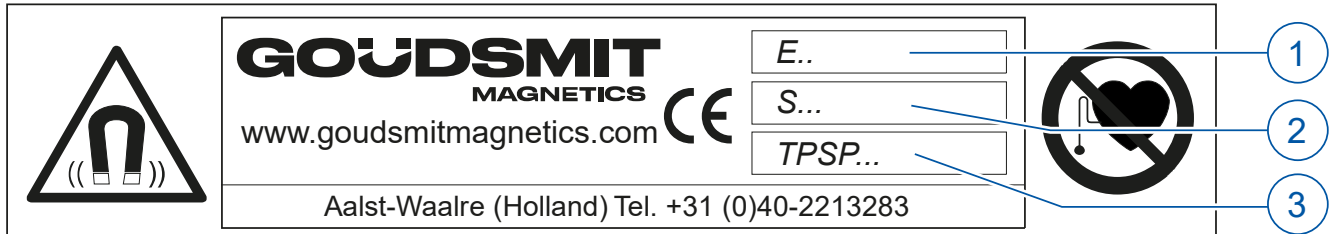

- [1] Article
- [2] Order number
- [3] Product key

6.4 Compressed air connections [5a/5b]

The device switches ON when port **5a** is pressurized and port **5b** is vented.

The device switches OFF when port **5b** is pressurized and port **5a** is vented.

6.5 Red indicator [1]

The red indicator shows whether the device is on or off.

If the red indicator is visible (extended), the magnetic field is on.

If the red indicator is not visible (retracted), the magnetic field is off.

6.6 Sensor connections [8a/8b]

The device is equipped with two sensors for on/off signalling [**8a + 8b**]. The sensors operate at 24 V nominal voltage and have a 3-wire switching output with N/O contact.

The sensors can be connected with Festo NEBU-M8 cables with 3-pin M8x1.3 connectors.

7 Transport and installation

7.1 Transport



DANGER

Risk of entrapment

Do not place your hands inside the crate during lifting.



WARNING

Note

The device permanently emits a magnetic force.

Observe the safety instructions for transport in the Safety risks [► 6] section.

7.2 Installation of the device



NOTICE

Take the following precautions:

- ▶ Work safely, provide ample work space and use dependable scaffolding, ladders and other tools so the device can be installed without any risks.
- ▶ The device permanently emits a magnetic force. See the Safety risks [► 6] section for the precautions that must be taken when working on the device.
- ▶ Only qualified personnel may work on the device.
- ▶ Ensure that there is sufficient clearance around the installation to install the device in the installation/structure and for operation, inspection and maintenance work to be carried out.
- ▶ Ensure that no external vibration is transferred to the device, as this can cause permanent loss of magnetic force.
- ▶ Only use lifting/hoisting tools that are in good condition, and do not exceed the lifting capacity of the tools.

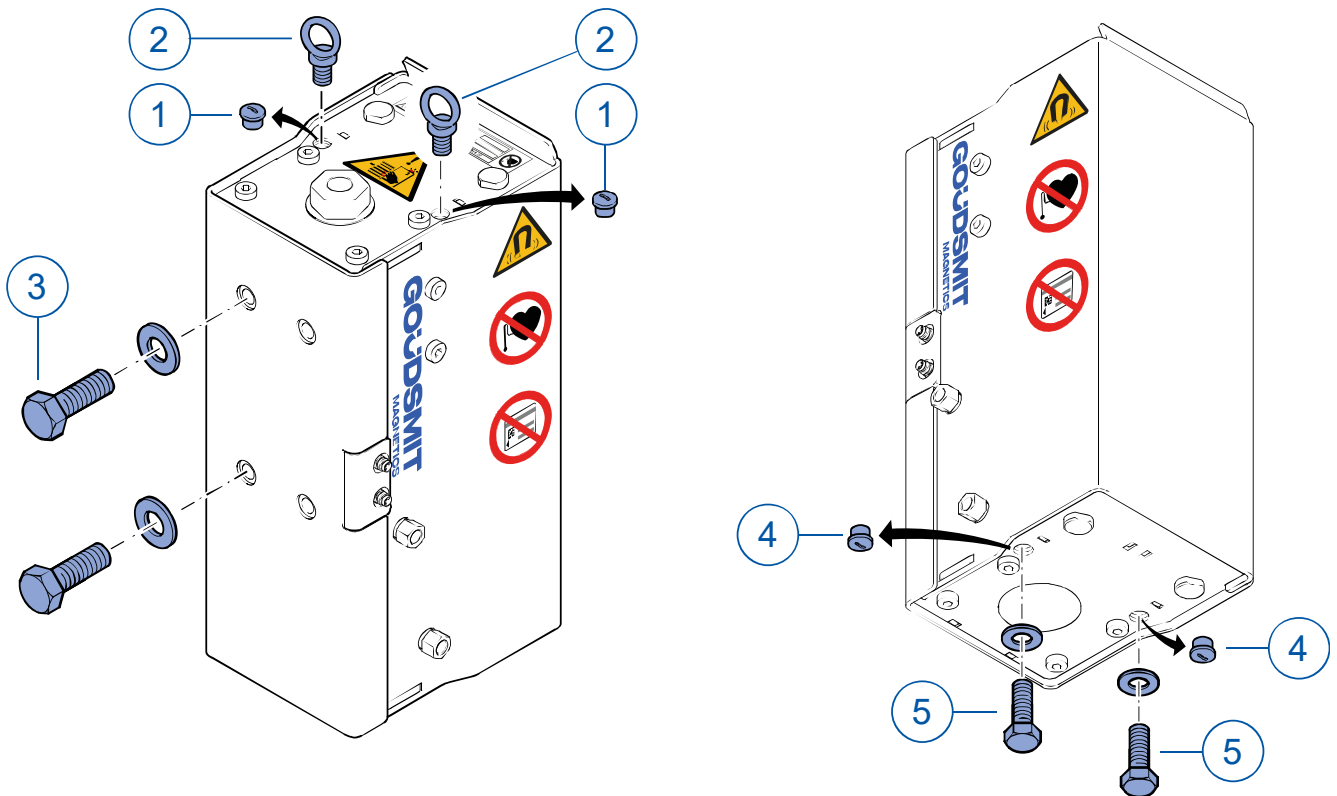

- The device is delivered in a crate. Open the crate and remove both protective caps [1].
- Fit an M12 eyebolt in both holes [2].
- Lift the device evenly out of the crate and transport it to the installation location. Use a suitable lifting/hoisting arrangement that supports the weight of the device.
- Attach the device with 2 x M12 bolts [5] (first remove the protective caps [4]) on the underside or with 4 x M8 bolts [3] to the back of your structure or robot arm.
- Screw the bolts into the device no more than 20 – 25 mm.

8 Commissioning

8.1 Connecting compressed air

Once the device is installed, the compressed air must be connected to put it into operation. Without air pressure, the magnet cannot be switched on, and there is virtually no magnetic field on the active surface. Once air pressure is applied to the device, the magnets rotate towards the active surface, creating a strong magnetic field.

Before starting up, check that:

- the device is not damaged or exhibiting any malfunctions.
- all connections (pneumatic, mechanical) have been correctly made.
- the device or installation has been correctly placed and positioned.
- all safety guards have been correctly fitted and all markings have been correctly applied.
- there are no other sources of danger.

During starting, check that:

- the device or installation is not exhibiting any malfunctions.
- all other parts of the device or installation are functioning as described.

Connection diagram

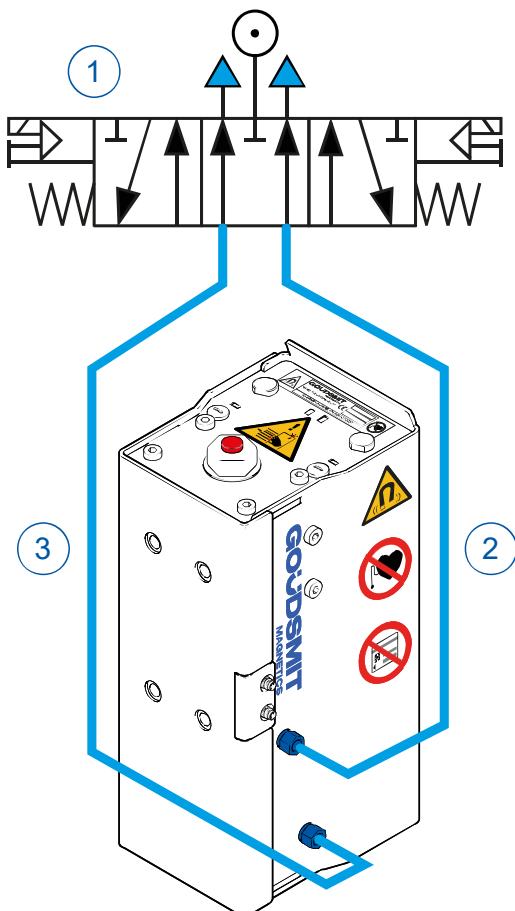

[1] 5/3 valve

[2] Magnet OFF

[3] Magnet ON

8.2 Connecting pneumatically

- Connect an air supply hose with a minimum diameter of Ø6 mm and a connector (G1/8" or G1/4") to the compressed air outlet connection (magnet OFF) [3] and inlet connection (magnet ON) [4] of the device.
- Pressurize the system (refer to the Compressed air [▶ 11] section for the correct operating pressure). The red indicator [1] rises out of the device, indicating that the magnet is active.
- Check if the device is functioning correctly.
- Check both compressed air connections [3+4] for air leaks.

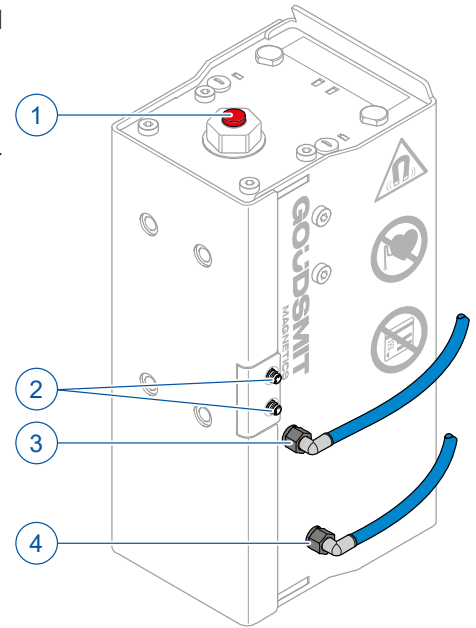

8.3 Magnet on/off signalling via sensors (optional)

Some devices can monitor the magnet's on/off operation using sensors.

- Connect both sensors to the (3-pin) 24 V connections [2]. For more information, see Sensor connections [8a/8b] [▶ 13] section.

9 Application and assembly examples

The devices can be positioned next to a stack of steel sheets in various ways, with one, two or multiple magnets at the same time. Experience will show which method works best. See examples below.

9.1 Assembly examples

Assembly is carried out using the threaded holes on the back of the device (see Installation of the device [▶ 14] section). The arrows on the diagrams indicate the recommended transport direction for the sheets after they have been separated by the device.

For **smaller sheets**, position the device in the centre of the shortest side.

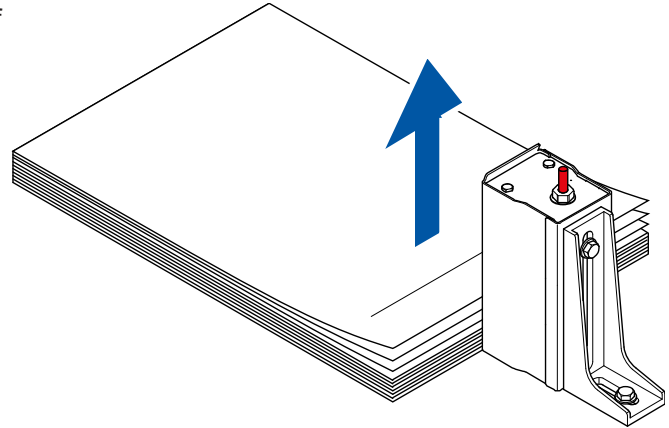

When the devices are placed **opposite each other**, the sheets will remain suspended.

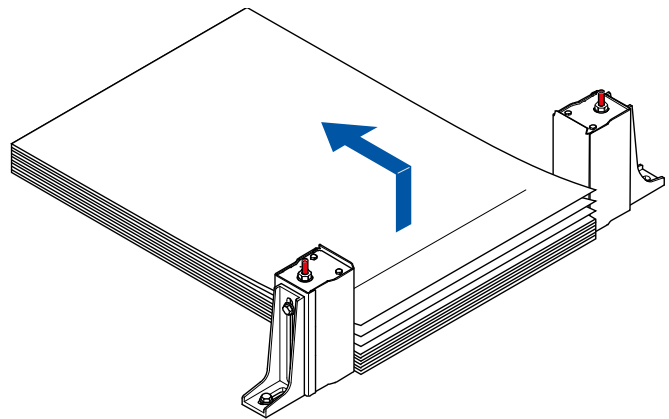

For a stack of **large steel sheets**, position the devices at the corners.

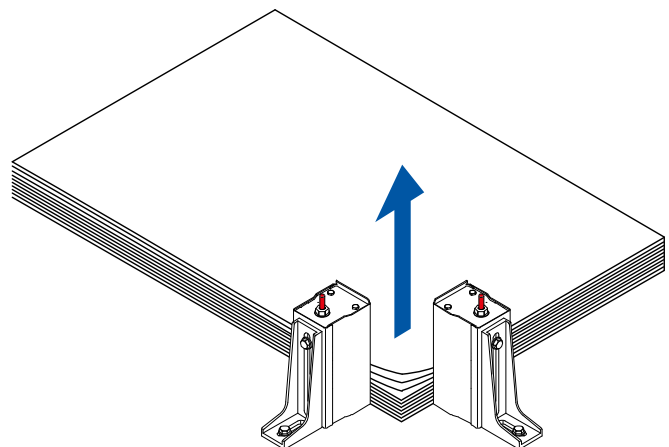

NOTICE

It is recommended to switch off the device when the steel sheet leaves the stack.

10 Maintenance and inspection



WARNING

Risk of crushing

In view of the large magnetic forces, replacing the internal magnet components is extremely dangerous as they are difficult to handle. Replacement may ONLY be carried out by appropriately qualified personnel or (ideally) by Goudsmit Magnetics technicians.

If the replacement is carried out by unqualified personnel, the warranty will be void.

Goudsmit Magnetics cannot be held liable for any consequential damage to people and/or materials if this prohibition is ignored.



WARNING

When performing maintenance, place the magnetic components on a non-ferromagnetic surface.



CAUTION

The compressed air must be switched off when work is being carried out on the device.

10.1 Periodic inspection and maintenance

- Always inform operating personnel of scheduled inspections, maintenance, repairs and in the event of faults.
- Check regularly that all warning pictograms are still present in the correct locations on the device. If the warning pictograms are lost or no longer legible, replace them with new pictograms in the original locations immediately.
- Ensure that the device is externally clean. Remove dust, dirt and particles from the device as appropriate.
- Check the outside of the device for any defects (e.g. loose air hose).
- Check the proper operation and performance of the sheet separator. Pay attention to any noticeable abnormalities, such as unusual noises, irregular switching speeds or leaks.
- Verify that all fastening bolts and parts are properly tightened.



NOTICE

Goudsmit Magnetics offers an annual maintenance inspection and an inspection report with certificate for the magnets.

11 Troubleshooting

Use the following table to search for faults, determine the possible cause and find the remedy. In the event of a fault that is not in the table, contact Goudsmit Magnetics customer service.

Problem	Possible cause	Solution
Magnet cannot separate the sheets, or does so poorly.	The active surface is dirty or damaged.	Clean the active surface more frequently.
	The sheets to be separated are too thick.	Order a magnet with a higher capacity. Maximum sheet thickness is 4 mm.
	The sheets to be separated are not or only weakly ferromagnetic.	Check the sheets that were not/poorly separated with a permanent magnet to determine if the load is not or only weakly attracted. For advice, contact Goudsmit Magnetics.
	The sheets may not be placed correctly near/against the device.	Place the sheets correctly (flat and evenly) against the device.
	Air pressure is too low.	Repair or replace the air connection, if necessary.
	Leak in the supply air hose.	Replace the air hose.
Device does not work.	No or too low air pressure.	Check the air pressure.
	Magnets in the device do not move, even though there is sufficient air pressure at the device.	Contact Goudsmit Magnetics.

12 Service, spare parts, storage and dismantling

12.1 Customer service

Have the following information to hand when contacting customer service:

- Data from the identification plate.
- Type and scope of the problem.
- Presumed cause.

12.2 Spare parts

The high quality of the products from Goudsmit Magnetics means that the device is highly reliable in operation.

Spare parts are typically parts subject to wear, such as the active surface that comes into contact with the steel sheets. For replacement of the active surface, contact Goudsmit Magnetic Systems B.V..

The contact details are provided on the title page of this document.

- When ordering, state the article and order numbers that appear on the identification plate.
- For further information, please contact us by +31 (040) 22 13 283 or consult our website.

12.3 Storage and disposal

Avoid direct sunlight and storage at high temperatures (above 70 °C).

Avoid extreme mechanical shocks, as the adjustment of the switching mechanism could be affected.

Disposal/recycling

When dismantling and/or scrapping the magnet product, keep in mind the materials from which the individual parts are made (magnets, iron, aluminium, stainless steel, etc.). This should ideally be done by a specialized company. Always observe the local regulations and standards pertaining to industrial waste disposal.

Inform those disposing of the magnet material of the hazards of magnetism. For more information, see the Safety risks [► 6] section.

